

Central Fan

NCF



Original instruction manual
EN INSTRUCTION MANUAL

Declaration of conformity	4
Figures	5
English	9

Declaration of conformity

EN English**Declaration of conformity**

We, AB Ph. Nederman & Co., declare under our sole responsibility that the Nederman product: NCF (Part No. **, and stated versions of **) to which this declaration relates, is in conformity with all the relevant provisions of the following directives and standards:

Directives

2006/42/EC, 2014/30/EU.

Standards

SS EN ISO 12100.

The name and signature at the end of this document, is the person responsible for both the declaration of conformity and the technical file.

14550128, 14550328, 14550728, 14550828, 14550928, 14551028, 14551228, 14551328, 14551428, 14551528

AB Ph. Nederman & Co.
P.O. Box 602
SE-251 06 Helsingborg
Sweden

Frank Christensen
VP Operations EMEA
2018-01-19



Figures

1



2

YY connection 230 V

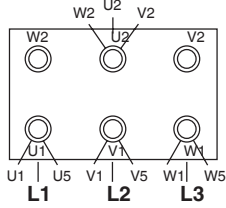

Y connection 460 V

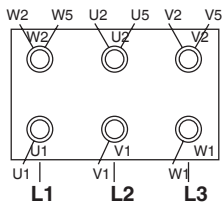

ΔΔ connection 230 V

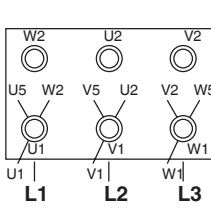

Δ connection 460 V

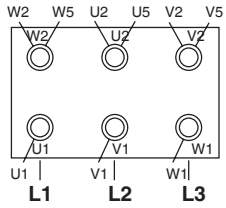

Δ connection 380 V

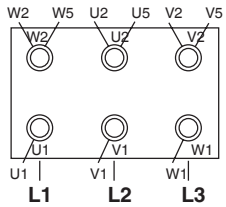

3

MOUNTING INSTRUCTION Vibration absorber

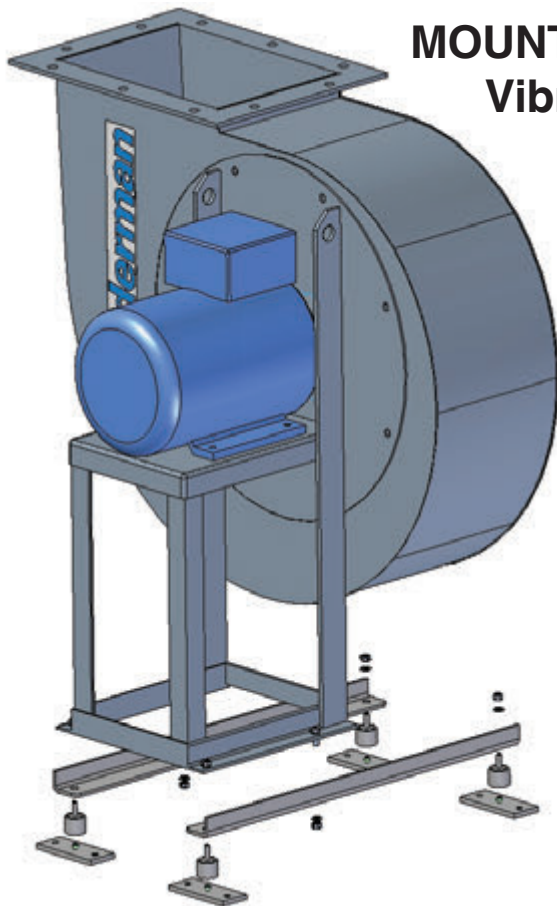

4

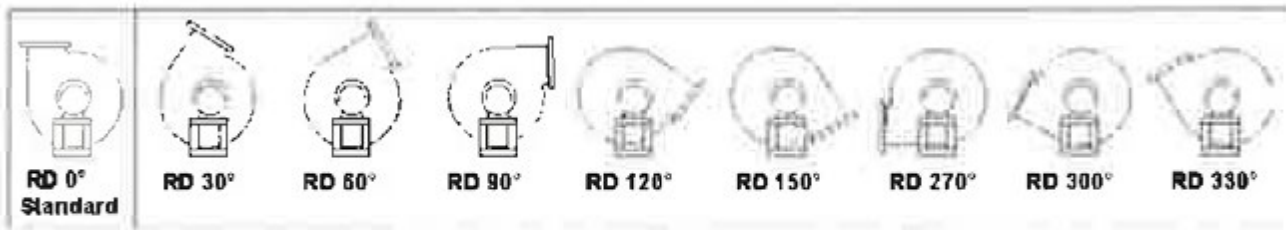

Outlet directions for all NCF fans except NCF 30/15.

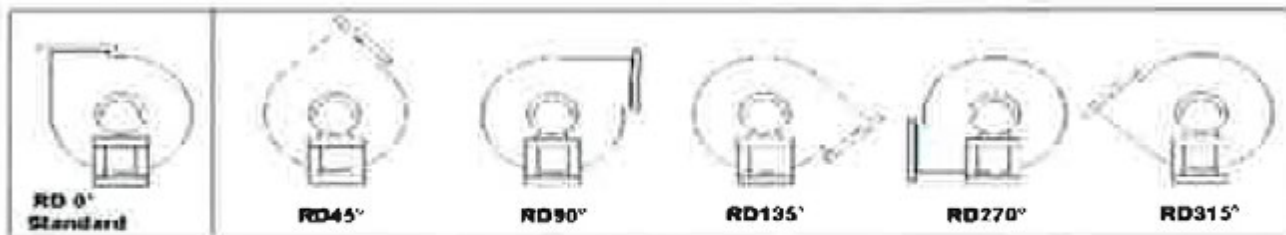

Outlet directions only for NCF 30/15.

5

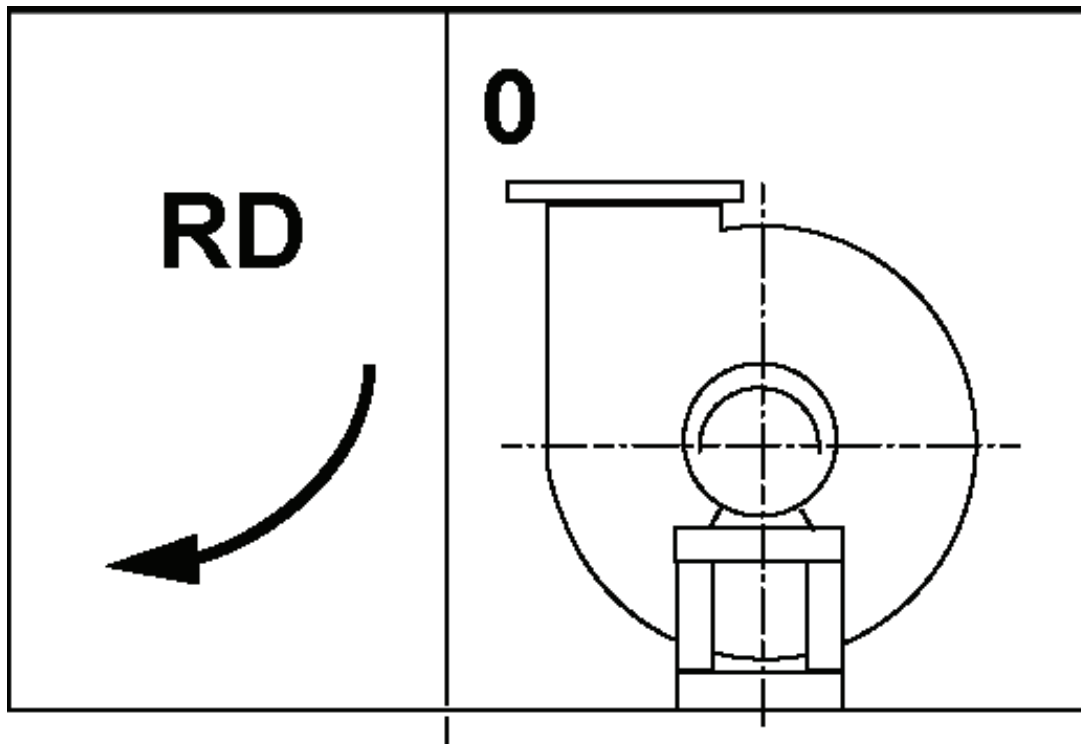

Standard outlet position.

6

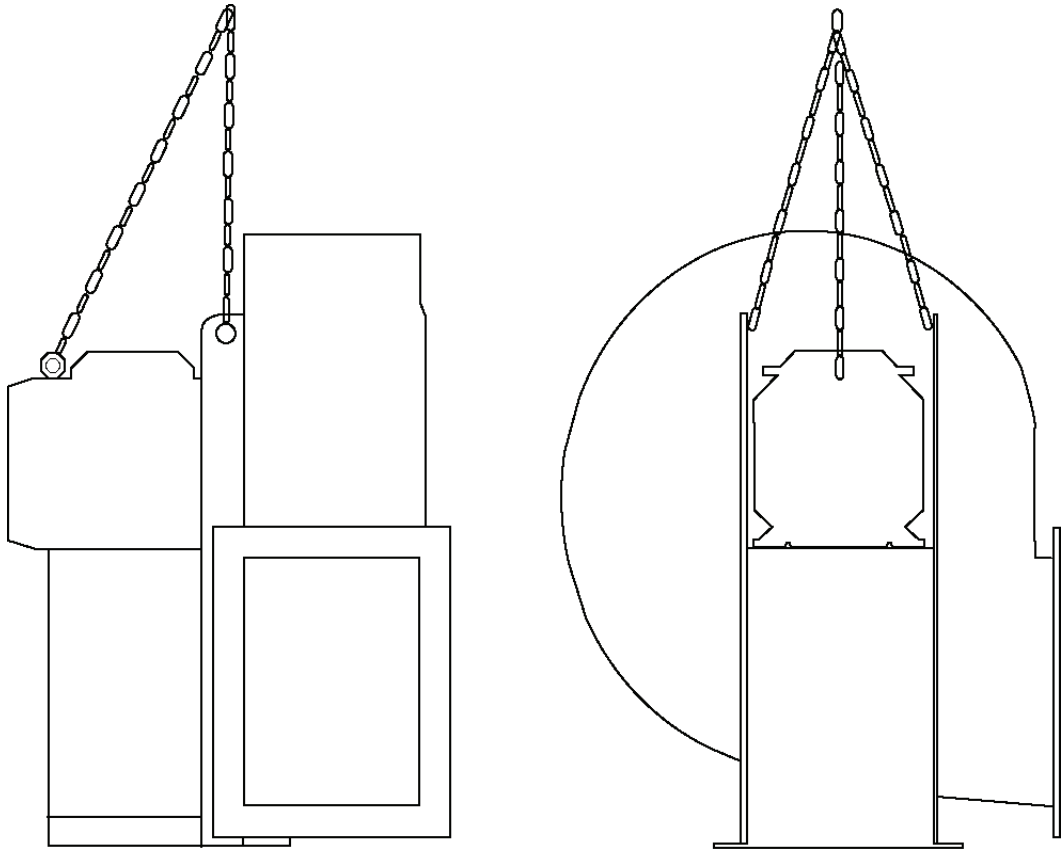

Example of lifting NCF fans.

7

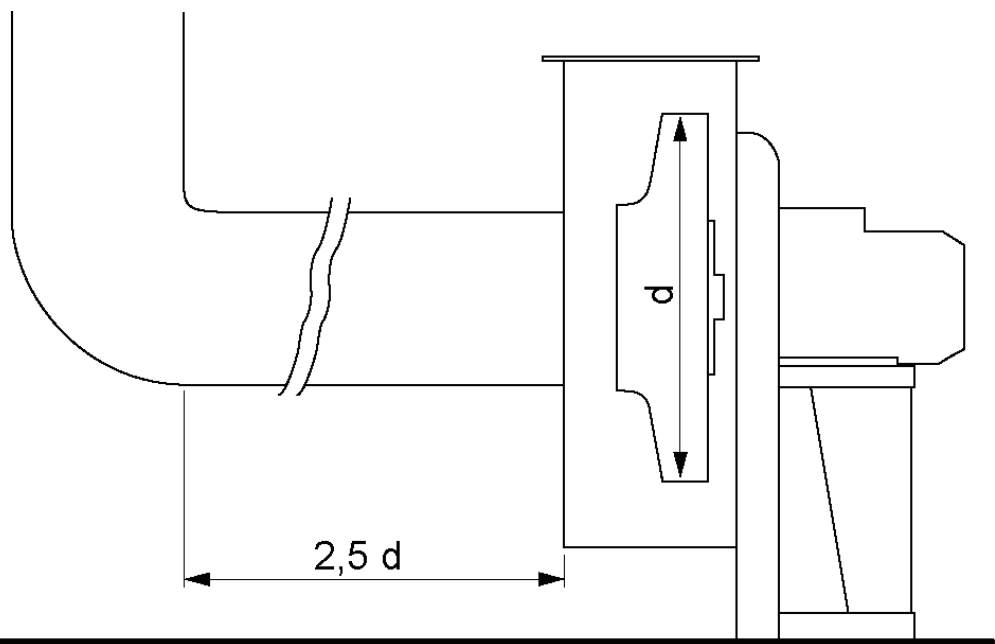

Minimum installation distances with intake pipe.

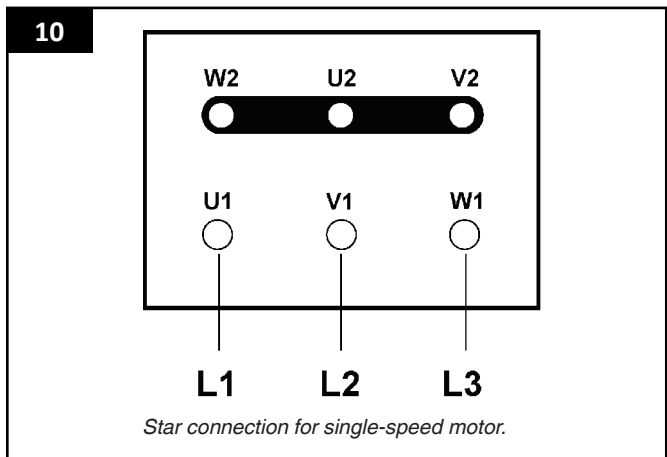
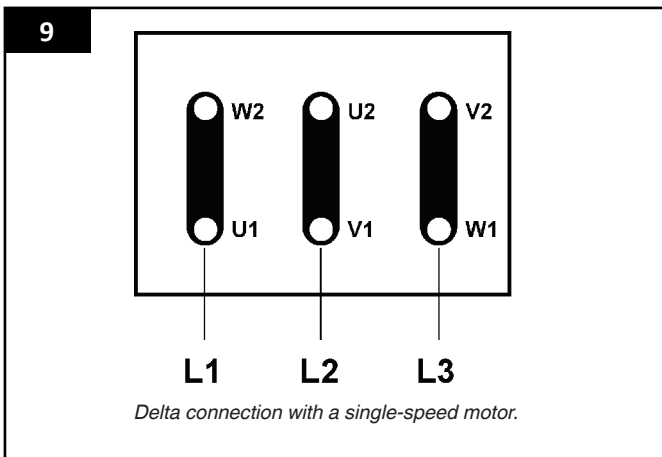
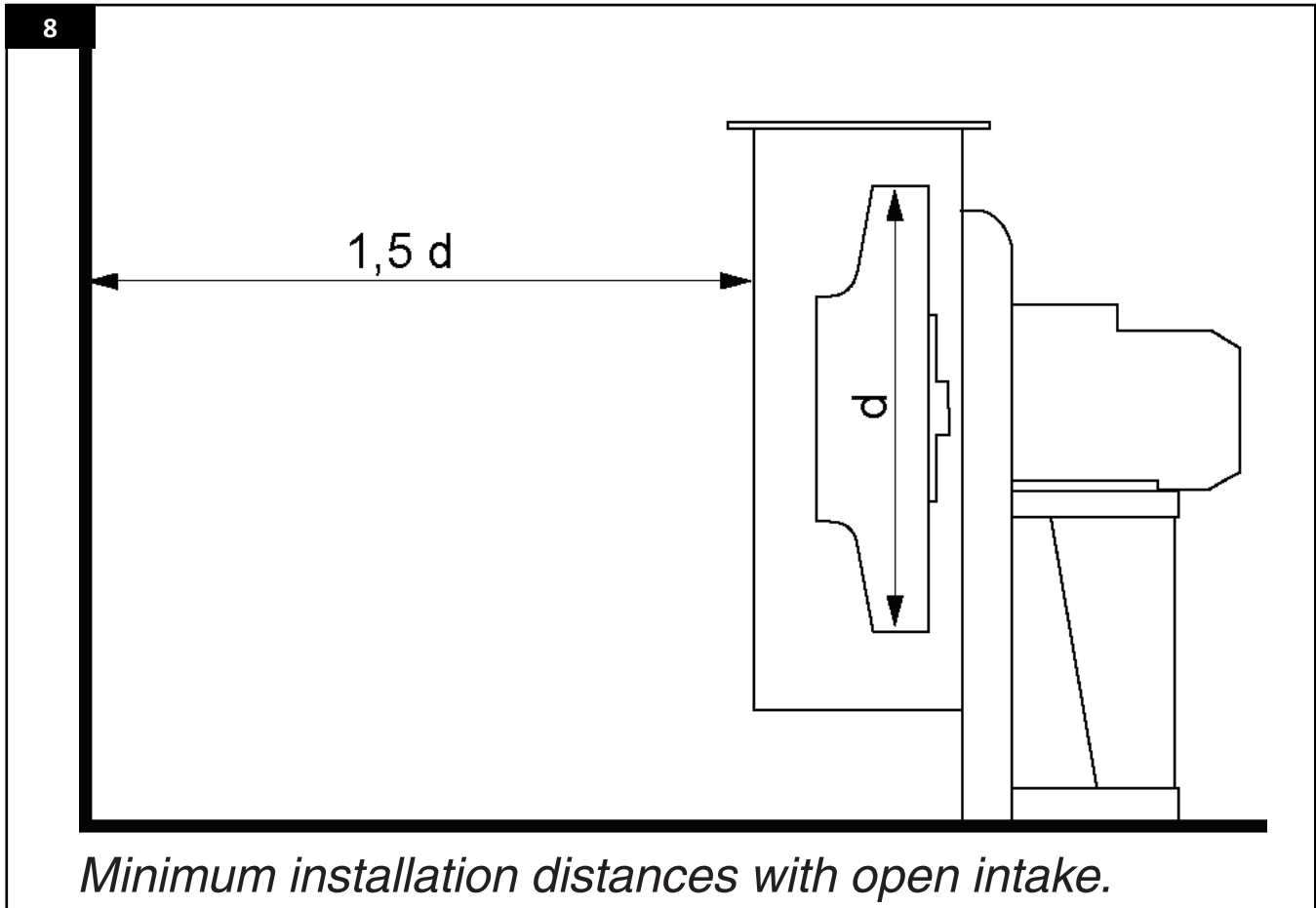

Table of contents

1	Preface.....	10
2	Safety.....	10
2.1	Installation.....	10
2.2	Risks involved in incorrect handling or use.....	11
2.3	Other risks related to fans.....	12
2.4	Specific risks involved in transport and installation.....	12
2.5	Specific risks involved in fan maintenance.....	13
3	Description.....	13
3.1	Technical specifications.....	13
3.1.1	Technical data 50 Hz fans (metric).....	13
3.1.2	Technical data 60 Hz fans (metric).....	14
3.1.3	Technical data 60 Hz fans, 380 V (metric).....	15
3.1.4	Technical data 60 Hz fans (imperial).....	15
4	Installation.....	16
4.1	Delivery check.....	16
4.2	General information.....	16
4.2.1	Fan orientation.....	16
4.2.2	Standard fan outlet position for NCF fans.....	16
4.3	Transport and installation.....	16
4.3.1	Transport and lifting.....	16
4.3.2	Storage in a warehouse.....	17
4.3.3	Lifting NCF fans.....	17
4.4	Installation.....	17
4.4.1	Minimum distances between components.....	18
4.4.2	Connections to pipes.....	18
4.4.3	Electrical connections.....	18
4.4.4	Delta connections.....	18
4.4.5	Star connections.....	18
4.5	Checks to be made before and after starting.....	19
4.5.1	Preliminary checks.....	19
4.5.2	Checks to be carried out with the fan running.....	19
4.6	Malfunctions and causes.....	19
5	Maintenance.....	20
5.1	Checking and cleaning parts in contact with the fluid.....	20
5.2	Disassembly.....	21
5.2.1	Intake nozzles.....	21
5.2.2	Housing.....	21
5.2.3	Fan rotor.....	21
5.3	Technical enclosures.....	22
5.4	Spare parts.....	22
5.5	Recycling.....	23

1 Preface

Read this manual carefully before installation, use and service of this product. Replace the manual immediately if lost. Nederman reserves the right, without previous notice, to modify and improve its products including documentation.

This product is designed to meet the requirements of relevant EC directives. To maintain this status, all installation, maintenance and repair is to be done by qualified personnel using only Nederman original spare parts and accessories. Contact the nearest authorized distributor or Nederman for advice on technical service and obtaining spare parts. If there are any damaged or missing parts when the product is delivered, notify the carrier and the local Nederman representative immediately.

2 Safety

This document contains important information that is presented either as a warning, caution or note:



WARNING! Risk of personal injury.

Warnings indicate a potential hazard to the health and safety of personnel, and how that hazard may be avoided.



CAUTION! Risk of equipment damage.

Cautions indicate a potential hazard to the product but not to personnel, and how that hazard may be avoided.



NOTE! Notes contain other information that is important for personnel.

2.1 Installation



WARNING! Risk of personal injury.

The safety measures adopted for using the fan must also be tailored to suit the specific applications for which the fan will be used. The safety measures taken differ depending on the type of fan installation. Therefore, the information in this manual is indispensable for the appropriate and hazard-free use of the fan.

There are four possible installation types, in compliance with UNI 10615 specifications:

- Type A: open intake and outlet.
- Type B: open intake and outlet connected to a pipe.
- Type C: intake connected to a pipe and open outlet.
- Type D: intake and outlet connected to a pipe.

Clearly AB Ph. Nederman & Co cannot be aware of which of these four installation types will be used by the user. Therefore, the installer or end client themselves must analyze the risks involved for the chosen installation type used in the specific application.

Depending on the applications that the client intends to use the fan for in the factory and on the type of installation chosen, the following safety shields must be fitted:

- Type A installation: fixed shields at the intake and outlet.
- Type B installation: shield fitted only at the outlet.
- Type C installation: shield fitted only at the intake.
- Type D installation: no shield at either the intake or outlet.

The shielding must be constructed to impede access to the parts of the fan that could cause injury. It must be robustly built enough to stand the vibrations and stress caused by the machine and by environmental conditions. It must be securely fixed in position by devices that will not become loosened by vibrations and that cannot be removed without the use of tools.

It is, in any case, the person installing the fan who is responsible for ensuring that adequate measures have been taken to prevent accidental contact with the fan's moving parts.

The installer and the user must also take into account other types of risks present, in particular those caused by foreign matter entering the fan and the aspiration of explosive, inflammable or toxic gases at high temperatures.

The user must also bear in mind the risks inherent in maintenance work, which must always be carried out in conditions of the utmost safety, with the fan separated from the motor or isolated using suitable equipment.

Once the installer and/or user has decided which installation type is to be used and all the above procedures have been applied, the machine can now be considered a "complete machine" as described by machine use regulations. An overall risk evaluation must be made.

2.2 Risks involved in incorrect handling or use

- Never, for any reason whatsoever, disable, remove, modify or render inoperative in any other way any of the safety, protective or control devices of any single component or of the fan itself.
- Never place hands, arms or any other part of the body near any moving part.
- Never extend any part of the body past the limits of the safety barriers. Do not use any means that will increase normal accessibility to the fan components.
- Never use the fan in atmospheres where there is a risk of explosion.
- Unauthorized operators must not attempt to rectify any malfunction of the fan and/or modify the functional characteristics or and installation type.
- After any unprogrammed maintenance operation that required the removal of shields, barriers or any other protective device, before restarting the fan ensure that all these components have been refitted and are fully functional.
- All protective and safety devices must be kept in perfect working order at all times. All indicative and warning plates fixed to the fan must also

be kept in perfect condition at all times and must never be removed or moved from their original position.

- When troubleshooting for the cause of any malfunction of the fan, ensure that all precautions described in this manual have been taken to prevent personal injury and/or damage to property.
- Remember to tighten every screw, bolt and lock ring of every component subject to adjustment or maintenance.
- Before starting the fan, ensure that all safety devices have been correctly installed and are in perfect working order; if the above is not the case, do not start the fan and inform the head of safety or department manager immediately.
- The operator must be equipped with Personal protection Equipments in accordance with current legislation; the use of bulky clothing and accessories (ties, loose sleeves, etc.) is prohibited.

2.3 Other risks related to fans

The following is a list of specific hazards related to the fan's mechanical characteristics.



WARNING! Risk of personal injury.

A person may receive injuries as a result of:

- Becoming caught up between a moving part and a stationary part, for example, between a fan rotor and the fan housing or any other stationary fan component.
- Becoming caught up between two moving parts, for example, between a belt and a pulley.
- Suction of a part of the body into the fan and subsequent contact with the shaft or rotor.
- Contact with a moving part, such as the rotor.
- An object becoming sucked into the intake of the fan and expelled at high speed from the outlet of the fan.
- Contact with surfaces of the fan at dangerous temperatures, for example, temperatures below -20°C or above +50 °C.
- Hazards caused by the overspeed of a fan component, which can lead to the breakage of parts of the machine.
- The aspiration of air at temperatures above the specified operating range, which can lead to the deformation and breakage of the housing.

2.4 Specific risks involved in transport and installation

- Before installation, the user must prepare a perfectly level surface onto which the fan will be mounted. If this surface is not perfectly level, this can cause abnormal vibrations in the fan. This can, over time, lead to the deformation and/or breakage of fan components with the subsequent expulsion at speed of broken parts: these expelled parts can cause even fatal injuries to any persons exposed.
- Before installation, the user must also prepare adequate connections to earth for the fan case or for the fan structure to prevent the build-up of electrostatic charges.
- All installed protective devices must remain fixed to the fan together with their respective fixings (screws, bolts, etc.). The removal of one or

more fixing may compromise the functionality and tightness of the safety shield.

- In its standard form, the fan is not intended for use in a potentially explosive environment.
- The installation location of the fan must be kept clean at all times. Any eventual oil or water spillages not caused by the fan must be removed immediately.
- The minimum installation distances specified in the manual must always be respected to ensure correct functionality without any further hazards. The incorrect positioning of a component can compromise the functionality of the fan.

2.5 Specific risks involved in fan maintenance

- During maintenance and cleaning of the fan rotor, be particular careful of the rotor. This can lead to parts of the body becoming trapped and seriously injured between the rotor itself and fixed parts of the fan housing.
- Even when the fan is disconnected from the power supply, the rotating parts can still turn due to any air movement through the fan. This air flow may be natural or may be caused by the current induced by another fan installed elsewhere in the connected tubing system. This can also lead to parts of the body becoming trapped and seriously injured between the rotor itself and fixed parts of the fan housing.
- A fan maintenance program must be drawn up and followed to prevent the mechanical failure or breakage due to wear or insufficient maintenance.

3 Description

3.1 Technical specifications

3.1.1 Technical data 50 Hz fans (metric)

See also figure 2.

Table 3-1: Technical data 50 Hz fans (metric)

	NCF 30/15	NCF 120/15	NCF 30/25	NCF 40/25	NCF 50/25	NCF 80/20	NCF 120/25	NCF 160/25
Capacity (m ³ /h)	1100 - 4400	5700 - 14400	1700 - 6500	2000 - 6700	1800 - 5900	2300 - 9100	3500 - 12400	4600 - 17900
Total pressure (Pa)	1840 - 700	2520 - 740	2440 - 920	3440 - 1410	4550 - 1690	3070 - 1150	4500 - 2000	5030 - 1880
Motor power (kW)	2,2	7,5	4	5,5	5,5	7,5	15	18,5
Speed (rpm)	2880 rpm	2930 rpm	2905 rpm	2925 rpm	2925 rpm	2930 rpm	2940 rpm	2940 rpm
Voltage (V) Current (A)	230Δ/400Y 7,9/4,55	230Δ/400Y 24,0/13,8	230Δ/400Y 13,6/7,8	230Δ/400Y 17,9/10,3	230Δ/400Y 17,9/10,3	230Δ/400Y 24,0/13,8	230Δ/400Y	230Δ/400Y
Voltage (V) Current (A)		400Δ/690Y 13,8/8,0	400Δ/690Y 7,8/4,5	400Δ/690Y 10,3/6,0	400Δ/690Y 10,3/6,0	400Δ/690Y 13,8/8,0		
Frequency (Hz)	50	50	50	50	50	50	50	50

See Figure 2.

	NCF 30/15	NCF 120/15	NCF 30/25	NCF 40/25	NCF 50/25	NCF 80/20	NCF 120/25	NCF 160/25
Phase:	3~	3~	3~	3~	3~	3~	3~	3~
Starting current	6 - 7 x rated current	6 - 7 x rated current	6 - 7 x rated current	6 - 7 x rated current	6 - 7 x rated current	6 - 7 x rated current	6 - 7 x rated current	6 - 7 x rated current
Degree of protection	IP 55	IP 55	IP 55	IP 55	IP 55	IP 55	IP 55	IP 55
Weight (kg)	67	123	105	110	112	150	232	292
Working temperature (°C)	Maximum +60	Maximum +60	Maximum +60	Maximum +60	Maximum +60	Maximum +60	Maximum +60	Maximum +60
Ambient temperature (°C)	30 to +40	30 to +40	30 to +40	30 to +40	30 to +40	30 to +40	30 to +40	30 to +40

See Figure 2.

3.1.2 Technical data 60 Hz fans (metric)

Table 3-2: Technical data 60 Hz fans (metric)

	NCF 30/15	NCF 30/20	NCF 30/25	NCF 40/25	NCF 50/25	NCF 80/20	NCF 120/15	NCF 120/25	NCF 160/25
Capacity (m³/h)	535 - 4180	700 - 4315	830 - 6000	910 - 6550	800 - 5600	1600 - 8540	2600 - 13980	2340 - 11650	2650 - 17140
Total pressure (Pa)	1970 - 575	2890 - 950	2540 - 870	3640 - 1320	4540 - 1570	3170 - 1020	3590 - 1170	5260 - 1700	5060 - 1870
Motor power (kW)	2,2	3,0	4,0	5,5	5,5	7,5	11	15	18,5
Speed (r/min)	3500	3515	3535	3510	3520	3550	3540	3550	3560
Voltage (V) Current (A)	208 8,6	208 11,5	208 15,1	208 18,7	208 18,7	208 26,2	208 38,4	208 52	208 66,4
Voltage (V) Current (A)	230YY/460Y 7,8/3,9	230YY/460Y 10,4/5,2	230ΔΔ/460Δ 13,6/6,8	230ΔΔ/460Δ 17/8,5	230ΔΔ/460Δ 17/8,5	230ΔΔ/460Δ 23,8/11,9	230ΔΔ/460Δ 34,8/17,4	30ΔΔ/460Δ 46,8/23,4	230ΔΔ/460Δ 60/30
Voltage (V) Current (A)	575 V 3,1 A	575 V 4,2 A	575 V 5,5 A	575 V 6,8 A	575 V 6,8 A	575 V 9,5 A	575 V 11,0 A	575 V 19,4 A	575 V 24 A
Frequency (Hz)	60	60	60	60	60	60	60	60	60
Phase	3 phase	3 phase	3 phase	3 phase	3 phase	3 phase	3 phase	3 phase	3 phase
Starting current	6-7 x rated current	6-7 x rated current	6-7 x rated current	6-7 x rated current	6-7 x rated current	6-7 x rated current	6-7 x rated current	6-7 x rated current	6-7 x rated current
Protection	IP 55	IP 55	IP 55	IP 55	IP 55	IP 55	IP 55	IP 55	IP 55
Weight (kg)	67	85	105	110	112	150	161	232	292
Working temperature (°C)	Maximum +60	Maximum +60	Maximum +60	Maximum +60	Maximum +60	Maximum +60	Maximum +60	Maximum +60	Maximum + 60 °C

See Figure 2.

	NCF 30/15	NCF 30/20	NCF 30/25	NCF 40/25	NCF 50/25	NCF 80/20	NCF 120/15	NCF 120/25	NCF 160/25
Ambient temperature (°C)	30 to +40	30 to +40	30 to +40	30 to +40	30 to +40	30 to +40	30 to +40	30 to +40	-30 °C to +40 °C

See Figure 2.

3.1.3 Technical data 60 Hz fans, 380 V (metric)

Table 3-3: Technical data 60 Hz fans (metric)

	NCF 30/15	NCF 30/20	NCF 30/25	NCF 40/25	NCF 50/25	NCF 80/20	NCF 120/15	NCF 120/25	NCF 160/25
Capacity (m³/h)			830 - 6000	910 - 6550	800 - 5600	1600 - 8540	2340 - 11650		2650 - 17140
Total pressure (Pa)			2540 - 870	3640 - 1320	4540 - 1570	3170 - 1020	5260 - 1700		5060 - 1870
Motor power (kW)			4,0	5,5	5,5	7,5	15		18,5
Speed (r/min)			3535	3510	3520	3550	3550		3560
Voltage (V) Current (A)			380Δ 8,2	380Δ 10,8	380Δ 10,8	380Δ 14,5	380Δ 27,9		380Δ 34
Frequency (Hz)			60	60	60	60	60		60
Phase			3 phase	3 phase	3 phase	3 phase	3 phase		3 phase
Starting current			6-7 x rated current	6-7 x rated current	6-7 x rated current	6-7 x rated current	6-7 x rated current		6-7 x rated current
Protection			IP 55	IP 55	IP 55	IP 55	IP 55		IP 55
Weight (kg)			105	110	112	150	232		292
Working temperature (°C)			Maximum + 60	Maximum + 60	Maximum + 60	Maximum + 60	Maximum + 60		Maximum + 60
Ambient temperature (°C)			-30 to +40	-30 to +40	-30 to +40	-30 to +40	-30 to +40		-30 to +40

See Figure 2.

3.1.4 Technical data 60 Hz fans (imperial)

Table 3-4: Technical data 60 Hz fans (imperial)

	NCF 30/15	NCF 30/20	NCF 30/25	NCF 40/25	NCF 50/25	NCF 80/20	NCF 120/15	NCF 120/25	NCF 160/25
Capacity (cfm)	315 - 2466	410 - 2540	490 - 3535	535 - 3855	470 - 3300	940 - 5025	1530 - 8230	1375 - 6855	1560 - 10090
Total pressure (in w.g.)	7.9 - 2.3	11.6 - 3.8 in w.g.	10.2 - 3.5	14.6 - 5.3	18.2 - 6.3	12.7 - 4.1	14.4 - 4.7	21.1 - 6.8	20.3 - 7.5
Motor power (hp)	3.0 hp	4.0 hp	5.5 hp	7.5 hp	7.5 hp	10 hp	15 hp	20 hp	25 hp
Speed (r/min)	3500 r/min	3515 r/min	3535 r/min	3510 r/min	3520 r/min	3550 r/min	3540 r/min	3550 r/min	3560 r/min
Voltage (V) Current (A)	208 8.6	208 11.5	208 15.1	208 18.7	208 18.7	208 26.2	208 38.4	208 52	208 66.4
Voltage (V) Current (A)	230YY/460Y 7.8/3.9	230YY/460Y 10.4/5.2	230ΔΔ/460Δ 13.6/6.8	230ΔΔ/460Δ 17/8.5	230ΔΔ/460Δ 17/8.5	230ΔΔ/460Δ 23.8/11.9	230ΔΔ/460Δ 34.8/17.4	230ΔΔ/460Δ 46.8/23.4	230ΔΔ/460Δ 60/30
Voltage (V) Current (A)	575 V 3.1 A	575 V 4.2 A	575 V 5.5 A	575 V 6.8 A	575 V 6.8 A	575 V 9.5 A	575 V 11.0 A	575 V 19.4 A	575 V 24 A

See Figure 2.

	NCF 30/15	NCF 30/20	NCF 30/25	NCF 40/25	NCF 50/25	NCF 80/20	NCF 120/15	NCF 120/25	NCF 160/25
Frequency (Hz)	60	60	60	60	60	60	60	60	60
Phase	3 phase	3 phase	3 phase	3 phase	3 phase	3 phase	3 phase	3 phase	3 phase
Starting current	6-7 x rated current	6-7 x rated current	6-7 x rated current	6-7 x rated current	6-7 x rated current	6-7 x rated current	6-7 x rated current	6-7 x rated current	6-7 x rated current
Protection	IP 55	IP 55	IP 55	IP 55	IP 55	IP 55	IP 55	IP 55	IP 55
Weight (lbs)	148	187	231	243	247	331	355	511	644
Working temperature (°F)	Maximum + 140	Maximum + 140	Maximum + 140	Maximum + 140	Maximum + 140	Maximum + 140	Maximum + 140	Maximum + 140	Maximum + 140
Ambient temperature (°F)	-22 to +104	-22 to +104	-22 to +104	-22 to +104	-22 to +104	-22 to +104	-22 to +104	-22 to +104	-22 to +104

See Figure 2.

4 Installation

See Figure 3

4.1 Delivery check

If there are any damaged or missing parts when the product is delivered, notify the carrier and the local Nederman representative immediately.

4.2 General information

4.2.1 Fan orientation

NCF fans can be built in 14 different orientations. The orientation of a fan is expressed as seen from the transmission side. See Figure 4.

4.2.2 Standard fan outlet position for NCF fans

The standard NCF fans are delivered as RD0, shown in Figure 5. Other positions can be delivered on request. Please contact your AB Ph. Nederman & Co representative for assistance.

4.3 Transport and installation

4.3.1 Transport and lifting

Lifting and handling the fan may create hazards for any persons in the vicinity; it is therefore important to follow the indications given by AB Ph. Nederman & Co and to use suitable equipment. All operations involving the lifting and handling of the fan must be carried out with the utmost caution, avoiding any knocks that could compromise the functionality or damage the fan components. Use only the specific lifting points on the fan and ensure that the fan's weight is distributed evenly.



NOTE! All installation and assembly work must be carried out only by specialized technicians.

**WARNING! Risk of personal injury.**

The user is responsible for the selection of equipment, ropes, belts and chains best suited for both load and functionality.

4.3.2 Storage in a warehouse

Should it be necessary to store the fan in a warehouse, it must be protected from atmospheric conditions, humidity, dust and any harmful substances present in the air.

**WARNING! Risk of personal injury.**

It is absolutely forbidden to:

- Carry out any maintenance work without first ensuring that the fan rotor is effectively stationary.
- Start any maintenance work on the fan (including lubrication) without first disconnecting the fan from the main power supply.
- Clean the fan while it is running.
- Open any shield or inspection hatch while the fan is running.

We recommend that you periodically check that the fan is in a good condition and turn the fan rotor manually approximately once a month to prevent the deformation of its bearings.

**WARNING!**

The examples given are generic examples as it is impossible to know in advance every possible configuration for lifting a NCF fan.

4.3.3 Lifting NCF fans

NCF fans are equipped with a motor. When lifting these fans, as well as using the specific holes in fan structure, the eyebolt for lifting the motor must also be used (as shown in Figure 6).

4.4 Installation

The fan does not require the preparation of a special machine bed for its installation. A well-leveled concrete surface that can support the weight of the fan is sufficient.



NOTE! Always use anti-vibration supports and couplings to prevent the transmission of vibrations while the fan is running.

The support base must be perfectly level and flat to prevent torsion effects or misalignment of the supports: if necessary, install metal shims between the machine base and the concrete surface to ensure a perfect fit. Use the factory-fitted anchoring points and take care not to deform the fan structure while tightening bolts.

All connecting tubing must be supported separately and must be axially aligned with the fan's intake and outlet nozzles, to prevent any deformation occurring while tightening the bolts.

**WARNING!**

All installation work must only be carried out by qualified and authorised personnel using suitable equipment.

4.4.1 Minimum distances between components

If the available space permits, in installations where the intake is connected to a pipe, we recommend fitting a straight length of pipe with a length approximately 2.5 times the diameter of the fan rotor, to guarantee correct air flow into the intake. See Figure 7.

With installations with an open air intake, we recommend leaving a distance equal to approximately 1.5 times the diameter of the fan rotor between the fan intake and the nearest wall or machine. See Figure 8.

4.4.2 Connections to pipes

Connections between the fan and pipes must be made ensuring that all components are correctly aligned and that there are no obstructions in the tubing caused by gaskets or flexible parts. The weight of the tubing must not be supported by the fan and care must be taken not to deform any part of the fan during tightening of the connections to the pipes.



NOTE! We do NOT recommend installations with an open air intake.

4.4.3 Electrical connections

The fan's power supply line must have a sufficiently high power rating.

Connection to the main power grid must only be carried out by qualified personnel. Also, the client is responsible for the entire electrical system up to motor terminal board.

We remind you of the importance of installing a safe connection to earth for the fan. The earth connection system must comply with legislation in effect in the country of installation and must be periodically checked by qualified personnel. Make the connection to earth before any other connection. Check that the connection layout is suited to the mains power voltage.

Usually, standard electric motors can run in both directions indifferently. To invert the direction of rotation, simply swap over any two power cables directly on the terminal board.

The client must also install an electrical disconnecting device near the fan so that maintenance personnel can have direct control over the power supply to the fan.



CAUTION! Risk of equipment damage.

The client and/or the installer of the electric system is responsible for choosing the equipment and cables used for connecting the fan electrically, based on the dimensions of the motor installed and the characteristics of the main power supply.

All work performed on the electrical system must only be carried out with the fan at rest and electrically disconnected from the mains. Before installing/starting up, ensure that the information on the identification plate on the motor is compatible with the main power supply

4.4.4 Delta connections

See Figure 9.

4.4.5 Star connections

See Figure 10.

4.5 Checks to be made before and after starting

4.5.1 Preliminary checks



WARNING! Risk of personal injury!

Preliminary checks must only be performed with the fan at rest and disconnected from the power supply.

When starting the fan for the first time, the following preliminary checks are necessary:

- Check that all bolts are correctly tightened (rotor, supports, foundation bolts, and transmission components).
- Check the lubrication of the fan and motor bearings; if necessary, regrease (see Chapter 5. *Maintenance*).
- Check that all rotating parts can turn freely.
- Check that there are not foreign objects inside the fan.
- Check that the fan turns in the correct direction: power the motor for a brief moment to see if it turns in correct direction indicated by the arrow on the fan housing; if necessary, invert the direction of rotation (see Section 4.4.3. *Electrical connections*).

You may now start the fan. With centrifugal fans, close off the air intake partially to reduce the power peak at start-up and the motor starting time.

4.5.2 Checks to be carried out with the fan running

Check that the power absorption does not exceed the value indicated on the motor identification plate, if it does; stop the fan immediately and contact the manufacturer.

The fan must run without excessive vibration and noise.

Check, with the fan at rest and at an outside air temperature of 20°C, that the bearings do not exceed the maximum operating temperature (maximum bearing temperature 70°C).

During the first few hours of operation, it is normal for the bearings to reach slightly higher temperatures, as long as they later stabilise at a lower value. In the event of overheating of the bearings, contact the Nederman technical assistance department.

After 3 - 4 operating hours, with the fan at rest and disconnected from the power supply, check again that all bolts are correctly tightened, the bearing temperature.

4.6 Malfunctions and causes

Table 4-1: Malfunctions and causes

Problem	Reason	Cause
Power absorption much lower than nominal value	Insufficient air flow	<ul style="list-style-type: none"> • Rotational speed too low. • Nozzle or tubing partially obstructed. • Fan rotor partially obstructed. • Pressure resistance offered by the system higher than the design value. • Fluid density higher than the design value. • Inverted direction of rotation.

Problem	Reason	Cause
High power absorption	Excessive air flow	<ul style="list-style-type: none"> Excessive rotational speed. Pressure resistance offered by the system lower than the design value. Fluid density higher than the design value.
High power absorption		<ul style="list-style-type: none"> Air flow already rotating in the opposite direction to the fan rotation direction. Motor power supply voltage lower than the value indicated on the identification plate. Faults in the motor windings.
Insufficient pressure		<ul style="list-style-type: none"> Rotational speed too low. Fluid density lower than the design value.
Fluctuating fan operation	Unstable air flow	<ul style="list-style-type: none"> Low air flow. Fluctuations in air flow due to fans working in parallel. Vortices in the air induced by equipment near the air intake.
Vibrations	Fluctuating fan operation	<ul style="list-style-type: none"> (see previous cause)
Vibrations	Unbalanced rotating components	<ul style="list-style-type: none"> Fan rotor wear. Deposits on the fan rotor.
Vibrations	Mechanical malfunction or defects	<ul style="list-style-type: none"> Contact between moving and stationary components. Intrinsic fault in the bearings. Malfunction of the bearings due to unbalanced rotor.
Excessive noise		<ul style="list-style-type: none"> Contact between moving and stationary components. Fluctuating fan operation. Electromagnetic fault in motor. Orifices or sharp angles in tubing.

5 Maintenance



CAUTION! Risk of equipment damage.

Use only Nederman original spare parts and accessories.

Read Chapter 2 Safety before carrying out maintenance.

Installation, repair and maintenance work is to be carried out by qualified personnel using only original Nederman spare parts. Contact your nearest authorized distributor or Nederman for advice on technical service.



CAUTION! Risk of equipment damage.

During any maintenance procedure, the fan must be disconnected and insulated from the electric power supply.

5.1 Checking and cleaning parts in contact with the fluid

The fan rotor should be cleaned regularly to prevent vibration caused by dust accumulating on the blades during operation. If the fan is used to pump even slightly dusty air, air containing abrasive powders or for the pneumatic transport material, the cleanliness and wear of the fan rotor must be

checked regularly. Dirt deposits on the rotor or wear of parts of the rotor can cause undesirable vibrations during fan operation. If any part of the rotor is excessively worn, it is imperative that the rotor be replaced (for this you must contact AB Ph. Nederman & Co's technical assistance service). For any information and before carrying out any modification to one of our fans, please contact the technical and quote the part number found on the fan identification plate.

 **NOTE!** An integrated maintenance program is necessary for normal and correct operation of the fan, and also ensures greater safety for the operator.

 **NOTE!** Regular cleaning and maintenance together with lubrication, are vital for ensuring correct operation and greater durability of the fan.

5.2 Disassembly



WARNING! Risk of personal injury!

All the disassembly and reassembly operations described below must only be carried out by qualified and authorised personnel. For no reason whatsoever must the operator or factory personnel carry out these operations.



CAUTION!

All the disassembly and reassembly work must be carried out with the following conditions:

- You must be absolutely certain that the fan is completely stationary (fan rotor at rest); disconnect the electrical power at the main panel with the switch, lock the switch with a padlock and hand the key to the head of maintenance.
- The working environment must be equipped with every tool necessary and must be free of any hazards.
- Every piece to be refitted must be thoroughly cleaned, degreased and lubricated as necessary before refitting.

5.2.1 Intake nozzles

Undo the nozzle securing nuts from the fan housing. Slide out the nozzle.

5.2.2 Housing

With all orientable fans, the housing is secured to the frame by bolts. Simply undo the securing nuts at the frame plate. With non-orientable fans with single-piece housings, the housing cannot be disassembled. The housing in certain fan types may be divided into two or more pieces, secured together by bolts.

5.2.3 Fan rotor

Remove the nozzle and, where possible, the fan housing. With single intake fans: remove the screw together with the lock-ring and use a suitably sized extractor. We recommend setting up a support for the rotor before extracting it completely. In any event, this operation must always be carried out with great care, avoiding any knocks that could alter the balance of the rotor or deform it.

5.3 Technical enclosures

Tightening torques for nuts and bolts

The tightening torques M given in the table are applicable in the following conditions:

- Hexagonal head UNI 5737 type screws, cylindrical head UNI 5931 and UNI 6107 type screws, in normal conditions in which they are supplied.
- Tightening torques must be applied slowly using a torque wrench.

While maintaining the same pre-load values, tightening torques must be modified as described below in the following cases:

- Increased by 5% for wide-head UNI 5712 screws.
- Reduced by 10% for zinc plated oiled screws.
- Reduced by 20% for phosphor coated oiled screws.
- Reduced by 10% if the screw is tightened with an impulse tightener.

Table 5-1: Tightening torques M for bolts with ISO metric thread

d x pitch (mm)	S r (mm ²)	8.8 M (Nm)	10.9 M (Nm)	12.9 M (Nm)
6 x 1	20,1	1. 10,4	2. 15,3	3. 17,9
7 x 1	28,9	17,2	25	30
8 x 1,25	36,6	25	37	44
10 x 1,5	58	50	73	86
12 x 1,75	84,3	84,3	127	148
14 x 2	115	115	115	115
16 x 2	157	214	314	368
18 x 2,5	192	306	435	509
20 x 2,5	245	432	615	719
22 x 2,5	303	592	843	987
24 x 3	353	744	1060	1240
27 x 3	459	1100	1570	1840
30 x 3,5	561	1500	2130	2500

5.4 Spare parts



CAUTION! Risk of equipment damage.

Use only Nederman original spare parts and accessories.

Contact your nearest authorized distributor or Nederman for advice on technical service or if you require help with spare parts. See also www.nederman.com.

Ordering spare parts

When ordering spare parts always state the following:

- Part number and control number (see the product identification plate).
- Detail number and name of the spare part (see www.nederman.com).
- Quantity of the parts required.

5.5 Recycling

The product has been designed for component materials to be recycled. Its different material types must be handled according to relevant local regulations. Contact the distributor or Nederman if uncertainties arise when scrapping the product at the end of its service life.

